



Series 41 Wedge Lok

DSCC 84103

RECOMMENDED GAP WIDTH

PCB + 5.33 (.210)

RECOMMENDED TORQUE

45 N-cm (4 in-lbs)

WEIGHT

.93 g/cm (.083 oz/in)

MATERIALS AND FINISH

WEDGES

Material:
Material:
Aluminum Alloy
6061-T6 per QQ-A-200/8
Finish:
See finish table on opposite page

SCREW

.09-in. or 2.5-mm hex. socket head cap screw, depending on mounting configuration

Material:
Series 300 stainless steel per QQ-S-763 ASTM A-582
Finish:
Passivated per AMS2700

OPTIONAL LOCK & FLAT WASHER

Material:
300 series stainless steel per QQ-S-763 and ASTM A-582
Finish:
Passivated per AMS2700

OPTIONAL LOCKNUT

Material:
Type A286 stainless steel per ASTM AMS 5525
Finish:
Silver plate per AMS 2410

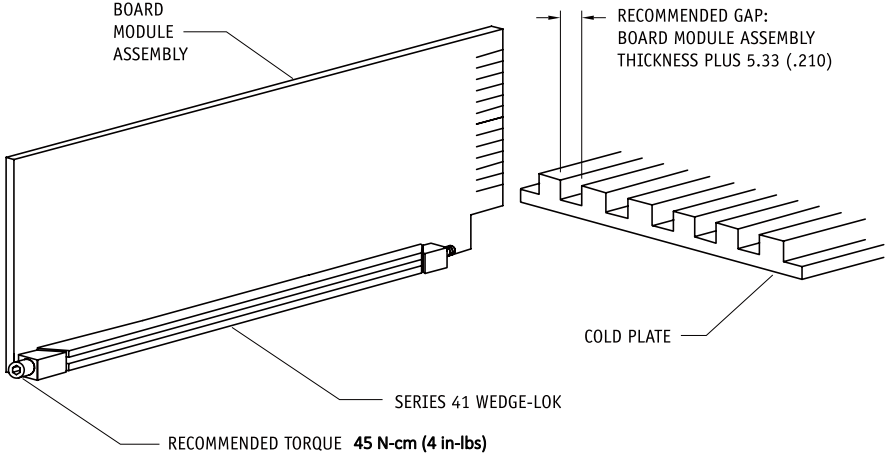
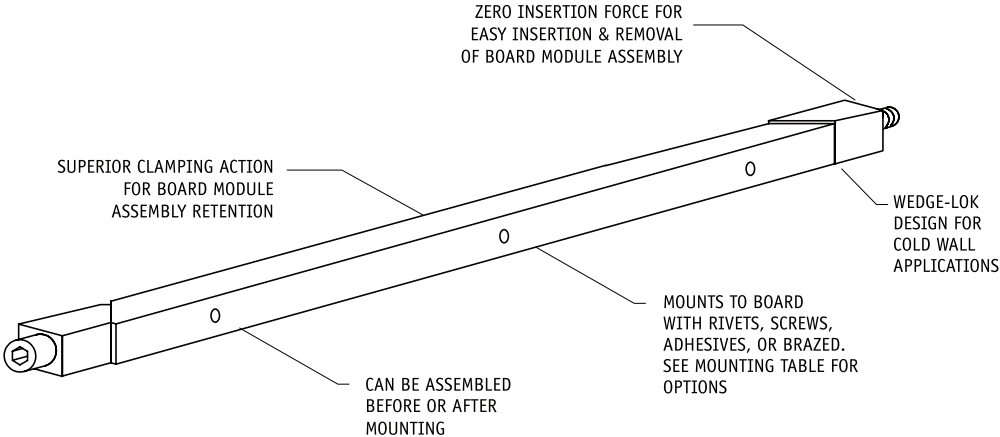

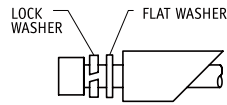

LF OPTION

Provides additional resistance to shock and vibration (adds 5.1 (.20) to screw length)

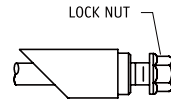

LN OPTION

Captivates rear wedge when untorqued (adds 2.5 (.10) to screw length)

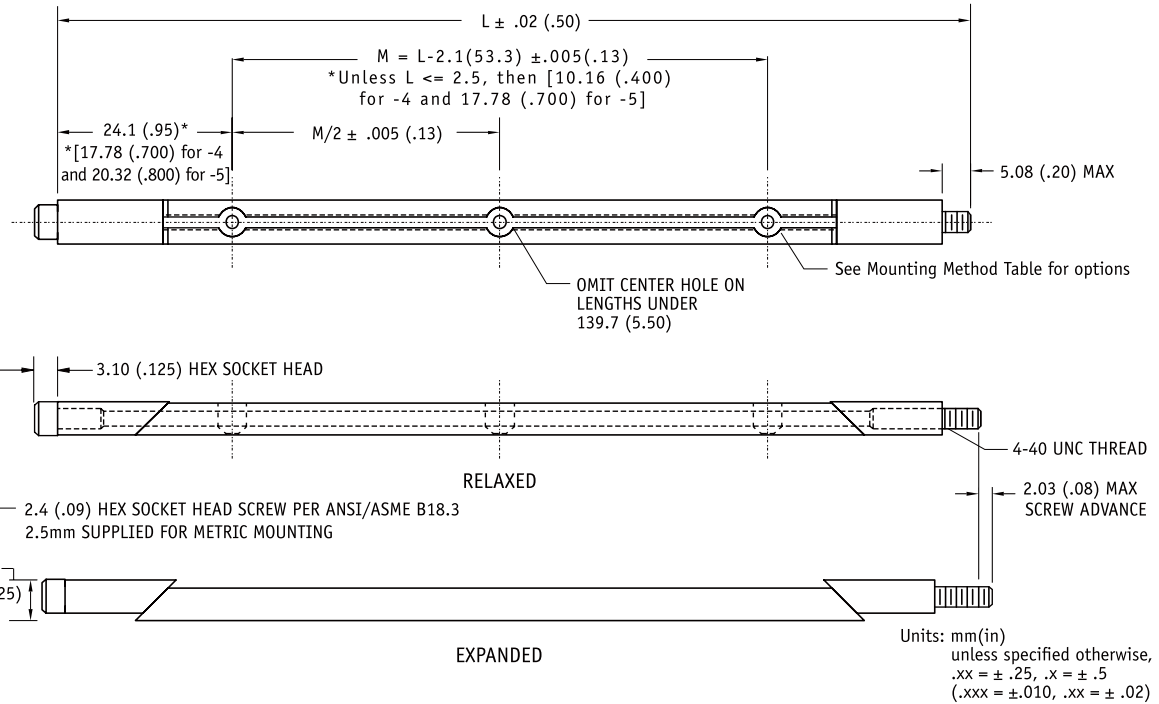

Part Number Code	
Series 41 WEDGE-LOK Three-piece	ZB-41-10-B-LF-LN-S-L
Length	
Length in 12.7 (.50) increments	4 [50.8 (2.00)]
	to 24 [304.8 (12.00)]
Finish	
BlackAnodized	B
Or select code letter from Finish Table	
Lock/Flat Washers and Locknut	
Lock Washer and Flat Washer	LF
None	[Blank]
Lock Nut	LN
None	[Blank]
Mounting	
2-56 UNC-2B Tapped Hole	T
Or select code letter from Mounting Method Table	
Lock Patch	
Lock Patch	L
None	[Blank]

FINISH TABLE

CODE	SURFACE FINISH
LETTER	
[blank]	CHEMICAL FILM PER MIL-C-5541, CLASS 1A, GOLD, N ON ROHS COMPLIANT
CC	CHEMICAL FILM PER MIL-C-5541, CLASS 1A, CLEAR
EN	ELECTROLESS NICKEL PER MIL-C-26074, CLASS 4, GRADE B, BRIGHT
N	NICKEL PLATE PER QQ-N-290, CLASS 1, GRADE G, BRIGHT
B	BLACK ANODIZE PER MIL-A-8625, TYPE II, CLASS 2
B3	HARD BLACK ANODIZE PER MIL-A-8625, TYPE III, CLASS 2
B3D	HARD BLACK ANODIZE WITH DRY FILM LUBE PER MIL- L46010

MOUNTING METHOD TABLE

CODE	METHOD
LETTER	
[blank]	RIVET MOUNT (Ø 1.70 + .10/- .03 (.067 + .004/.001) THRU L J Ø 3.96 (.156) ± 3.30 (.200) √ Ø 3.56 (.140) x 100 °)
A	NO MOUNTING HOLES
S	2-56 UNC-2B TAPPED HOLE
T	0-80 UNF-2B TAPPED HOLE
M2	M2 X .40 TAPPED HOLE
M	M2.5 X .45 TAPPED HOLE
NOTE:	RIVET (BLANK) PARTS ARE SHIPPED UNASSEMBLED

Part Number Code example: ZB-41-8-LF

Series 41 WEDGE-LOK Three-piece, 101.6-mm (4.00-in.) long, chem film finish, with Lock Washer and Flat Washer option, and standard rivet hole mounting.