

変更 REVISIONS			
回数 REV. MARK	日付 DATE	記事 CONTENTS	変更者 REVISED BY

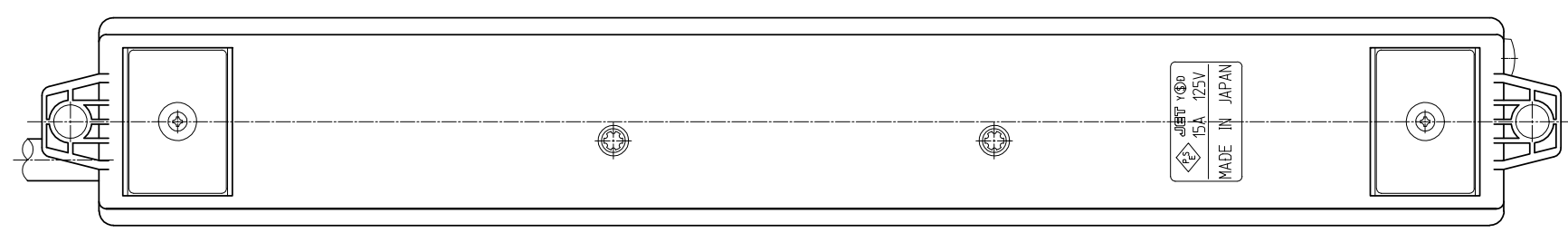

1	03		プラグ	PVC	「白」: 15A 125V
1	02		電源コード	VCTF	「白」: 2mm ² 2根(白・黒), 0.75mm ² 1根(黄/緑)
1	01		OAタップ(マグネット有リ)	ABS/UM-E	ホワイト/グレイ
個数 QUANTITY	No.	図番 DRAWING No.	部品名 PART NAME	材質 MATERIAL	仕上 FINISH
			設計 DESIGNED	検 CHECKED	承認 APPROVED
		単位 UNIT	図名 TITLE		
		尺度 SCALE	品名 NAME		
			型式 MODEL		
			図番 DRAWING No.		

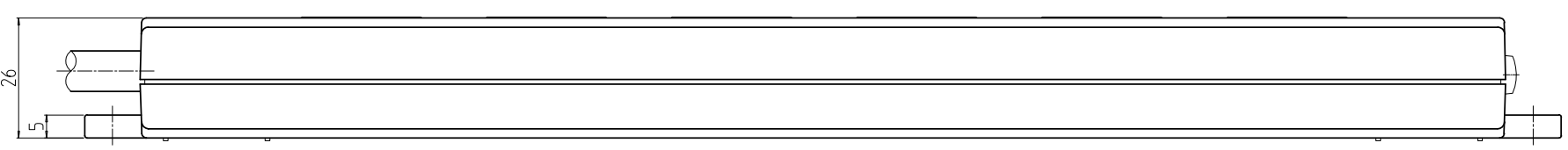
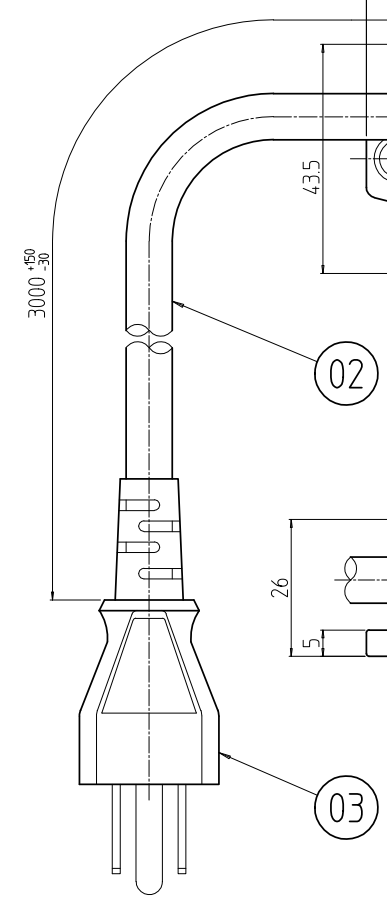
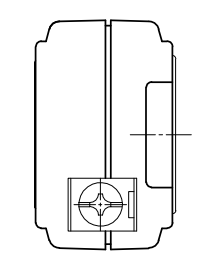
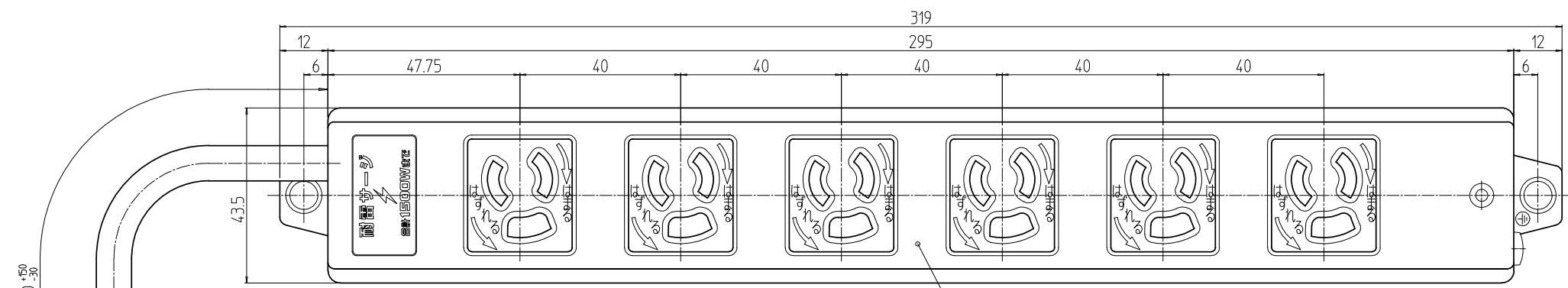
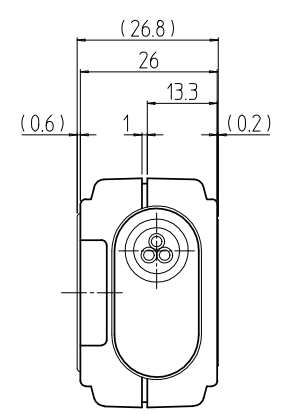
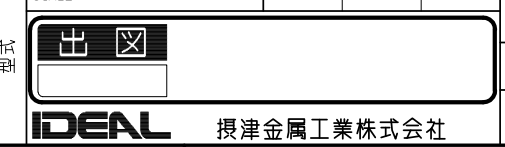

外觀寸法
DHT 耐サージ機能付OAタップ
DHT-T5224

DHT-040211